

## 操作指引

### 壹 功能說明

#### 控制台

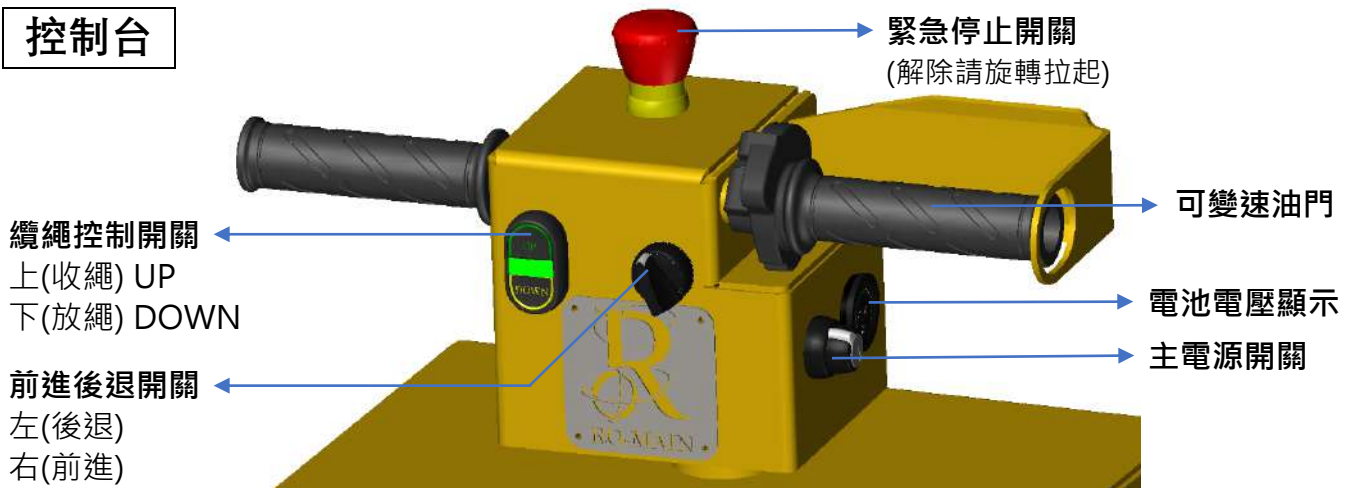

#### 吊掛手臂



吊掛臂角度調整器

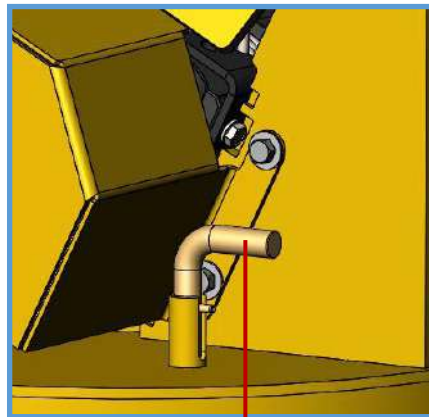

吊掛台旋轉固定插銷

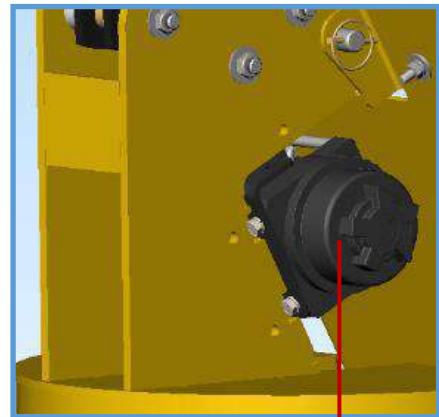

纜繩馬達離合器

#### 實心輪鎖(前輪)

(行駛中請將兩前輪一邊上鎖，另一邊解鎖。依輪胎磨損情形輪流上鎖)

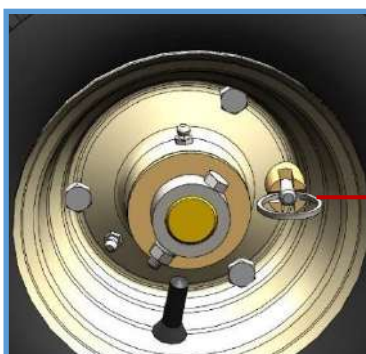

解鎖

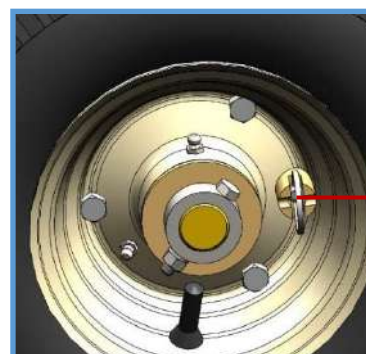

上鎖

## 貳 使用說明

### 1. 使用前安全確認

請確認操作大力士手臂的路面，**禁止在過度傾斜路面上操作大力士手臂以免翻覆發生危險。**  
轉動吊掛台後，務必使用"吊掛台旋轉固定插銷"固定吊掛台，確保吊掛台穩定。

### 2. 使用步驟

<p>1</p> 	<p>2</p> 	<p>3</p> 
<p>將吊掛臂調整至與斜板成一直線。</p>	<p>將大力士手臂行駛至需搬運地點。</p>	<p>將吊掛台旋轉 90 度對準斃死豬。</p>
<p>4</p> 	<p>5</p> 	<p>6</p> 
<p>鬆開 "纜繩馬達離合器"，將纜繩套在斃死豬頸項上，並鎖上 "纜繩馬達離合器"。</p>	<p>將 "安全桿" 架在豬欄上，避免機台前傾。</p>	<p>按 "纜繩控制開關(上)"，將斃死豬吊起。</p>
<p>7</p> 	<p>8</p> 	<p>9</p> 
<p>收起 "安全桿"，並將吊掛台轉正。</p>	<p>至指定區域放下斃死豬。</p>	<p>使用完請充電，以延長電池壽命。</p>

## 參 大力士手臂安全吊掛重量範圍

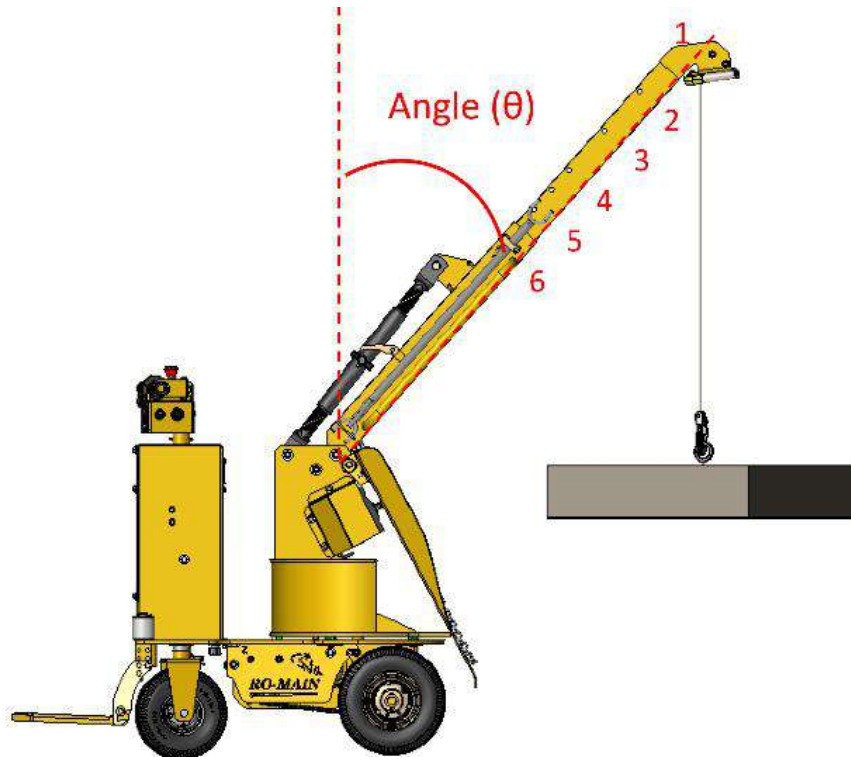

吊臂長度	吊臂角度(θ)			
	15 度	30 度	45 度	50 度
1	460	160	105	95
2	400	145	95	85
3	350	130	85	80
4	285	115	75	70
5	240	100	65	60
6	200	85	60	55

單位：公斤

\*\*吊掛物品模式(不使用安全桿)

